

# ABIMIG<sup>®</sup> A & AT Lightweight MIG Air-cooled MIG Guns



# ABIMIG® AT LW MIG Guns

## Air cooled • Up to 400 A

**Welding professionals do some of the most physically demanding jobs in metalworking and fabrication today.**

Welders have to constantly adapt their posture to effectively access their work, while simultaneously focusing on maintaining a solid welding arc at all times.

This heavy physical strain can lead to body and joint pain, and potentially create chronic, lifetime discomfort.

For this reason, every welder wants a robust welding torch that can perform the job needed, but also is both light and powerful, and is equipped with a torchneck that has been optimized for the job.

The new air-cooled welding torch series from ABICOR BINZEL - the ABIMIG AT LW - makes the weld life easier.

The "T" interface system allows for rotating torch necks with angles and alignments that are matched to the actual welding job. The necks can be quickly switched out for easy

maintenance and improved accessibility.

With our lightweight Bikox cable and ergonomic molded handle with ball socket base and extended trigger, getting comfortable on the job is now easier than ever.

ABIMIG AT is air-cooled perfection. Welding as it should be.

Find out for yourself.

### ABIMIG® AT 255 LW

#### Technical data (EN 60 974-7):

##### Rating:

Duty cycle: 60%

CO<sub>2</sub> 230 A

Mixed gases 220 A

M21 (DIN EN 439)

Wire size: 0.8 - 1.2 mm (.030" - .045")

### ABIMIG® AT 355 LW

#### Technical data (EN 60 974-7):

##### Rating:

Duty cycle: 60%

CO<sub>2</sub> 340 A

Mixed gases 310 A

Wire size: 0.9 - 1.6 mm (.035" - .062")

### ABIMIG® AT 415 LW

#### Technical data (EN 60 974-7):

##### Rating:

Duty cycle: 60%

CO<sub>2</sub> 400 A

Mixed gases 355 A

M21 (DIN EN 439)

Wire size: 0.9 - 2.4 mm (.035" - .094")



# Ordering Chart

A	T	3	15	T	-	35	L1	T
Torch Model	Handle	Amperage	Cable Length	Nozzle	Wire Size	Back End	Type	
<b>Torch Model</b> A - ABIMIG®	<b>Handle</b> T - Rotating Neck	<b>Amperage</b> 2 - 200 Amp (255 Model) 3 - 300 Amp (355 Model) 4 - 400 Amp (415 Model)	<b>Cable Length</b> 10 Feet 15 Feet 20 Feet 25 Feet	<b>Nozzle</b> T - Threaded	<b>Wire Size</b> 35 - .035 Inches <sup>1</sup> 45 - .045 Inches 52 - .052 Inches <sup>2</sup> 62 - .062 Inches <sup>2</sup> 78 - .078 Inches <sup>3</sup> 94 - .094 Inches <sup>3</sup>	<b>Back End</b> E - Euro L - Lincoln External gas L1 - Lincoln 10, PF74/84 L2 - Lincoln Power MIG HT - Hobart/Tweco M - Miller Standard M1 - Miller Multimatic <sup>2</sup> X - No connector kit installed	<b>Type</b> T - Extended Trigger	

<sup>1</sup> - 255 & 355 Models  
<sup>2</sup> - 355 & 415 Models  
<sup>3</sup> - 415 Model Only

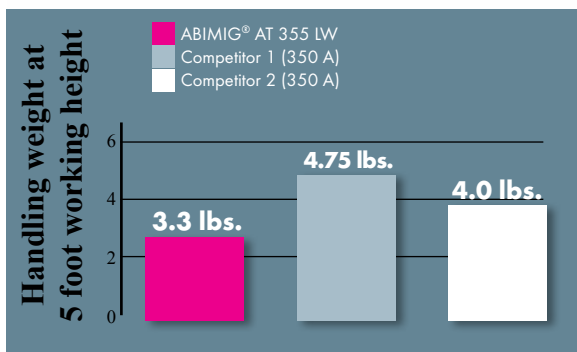
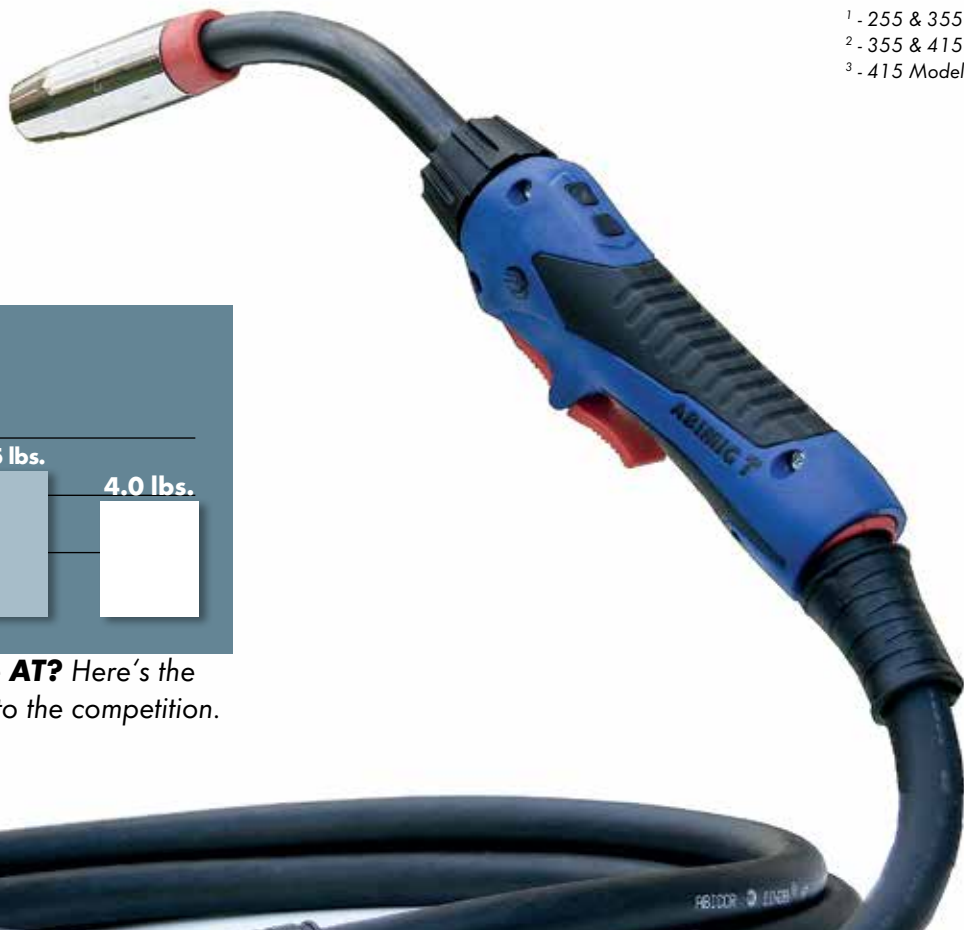

**How Lightweight is the AT?** Here's the weight average compared to the competition.

# ABIMIG® AT LW MIG Guns

## Body Cable Assembly - ABIMIG AT

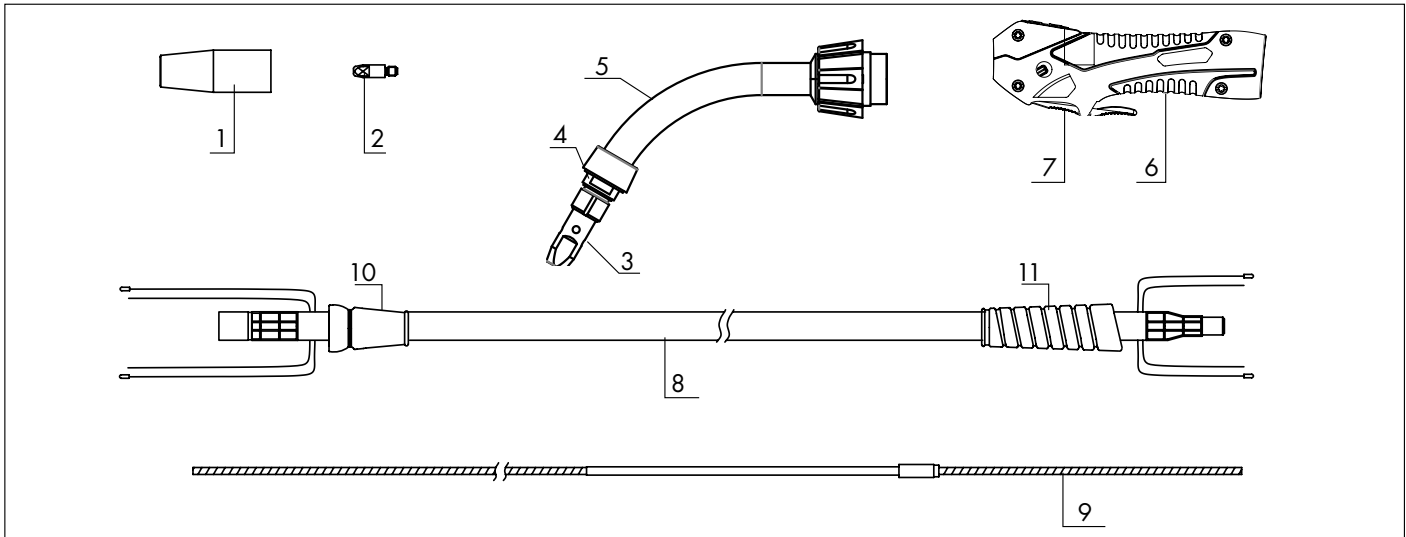

**ABIMIG AT 255**  
**Part No.**

**ABIMIG AT 355**  
**Part No.**

**ABIMIG AT 415**  
**Part No.**

Item No.	Description	Part No.	Part No.	Part No.
1	Nozzle			
2	Contact Tip			
3	Tip holder/Diffuser	See Page 9 & 10 for complete list of ABIMIG AT and ABIMIG A consumables.		
4	Adapter Piece			
5	Standard Swanneck (x -135, y -115, 60D)	004.0709	-	-
	Standard Swanneck (x -165, y -110, 60D)	-	014.0570	-
	Standard Swanneck (x -160, y -130, 60D)	-	-	016.0039
6	Handle Complete	180.D077	180.D077	180.D077
7	Trigger only	185.D118	185.D118	185.D118
8	Bikox 10 feet (415 cable shown)	160.H238	160.H046	160.H344
	Bikox 15 feet	160.H242	160.H248	160.H377
	Bikox 20 feet	160.H433	160.H397	160.H442
	Bikox 25 feet	160.H263	160.H265	160.1395
9	Liner	See Page 9 & 10 for complete list of ABIMIG AT and ABIMIG A consumables.		
10	Cable Support Front	400.D574	400.D574	400.D574*
11	Cable Support Rear	400.1010	400.1010	400.D518*
N/S	Contact Tip Wrench	191.0001	191.0001	191.0001

\*Cable Support Front and Rear are included in ABIMIG AT 415 as part of #8 Bikox cable.

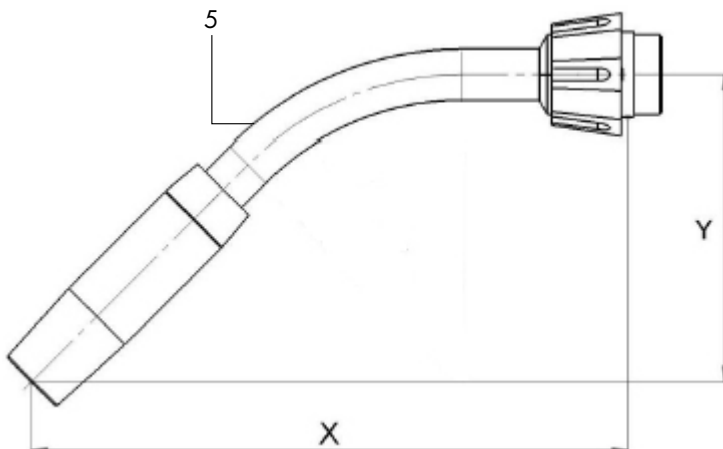

Change out torch necks in seconds and get back to doing what you love - welding.

AT's Average Neck Change Time: **<1 min.**

Standard MIG Neck Change Time: **30 min.**

# Swannecks - Short, Long, 180 Flex, & Extra Long

**014.H538**

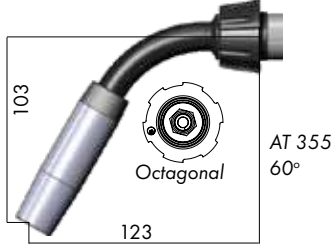

**016.D435**

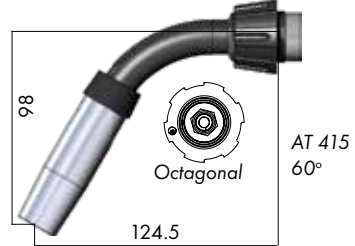

**014.H534**



**016.D410**



**014.0630**



**014.H515**



**014.H494**



**014.H500**

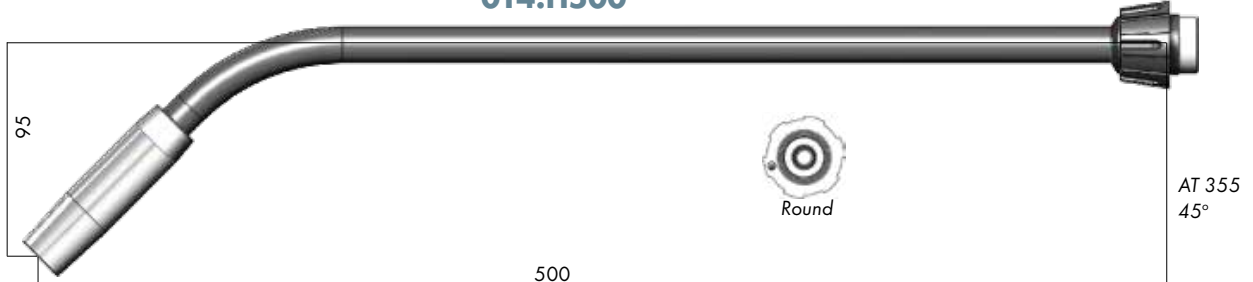

# ABIMIG® A LW MIG Guns

Air cooled • Up to 400 A



## ABIMIG A 255 LW

Technical data (EN 60 974-7):

Rating:

Duty cycle: 60%

CO<sub>2</sub> 230 A

Mixed gases 220 A

M21 (DIN EN 439)

Wire size: 0.8 - 1.2 mm (.030" - .045")

## ABIMIG A 355 LW

Technical data (EN 60 974-7):

Rating:

Duty cycle: 60%

CO<sub>2</sub> 340 A

Mixed gases 310 A

M21 (DIN EN 439)

Wire size: 0.9 - 1.6 mm (.035" - .062")

## ABIMIG A 415 LW

Technical data (EN 60 974-7):

Rating:

Duty cycle: 60%

CO<sub>2</sub> 400 A

Mixed gases 355 A

M21 (DIN EN 439)

Wire size: 0.9 - 2.4 mm (.035" - .094")

For a fixed neck and lightweight air-cooled welding option, the **ABIMIG A** offers the same lightweight and ergonomic handle design of the rotating AT. For comfort, our handle is contoured for the welder's hand, and the ball socket base creates a greater range of motion in the wrist than most welding torches on the market.

Combining this comfort with the lightweight Bikox cable assembly assures an easy to operate gun.

And, with the high quality BINZEL consumables, you will churn through less parts while saving on time and cost.

Welding as it should be. Designed with the welder in mind.

# Ordering Chart

<b>A</b>	<b>F</b>	<b>3</b>	<b>15</b>	<b>T -</b>	<b>35</b>	<b>L1</b>	<b>S</b>
<b>Torch Model</b>	<b>Handle</b>	<b>Amperage</b>	<b>Cable Length</b>	<b>Nozzle</b>	<b>Wire Size</b>	<b>Back End</b>	<b>Handle</b>
<b>Torch Model</b> A - ABIMIG®	<b>Handle</b> F - Fixed Neck	<b>Amperage</b> 2 - 200 Amp (255 Model) 3 - 300 Amp (355 Model) 4 - 400 Amp (415 Model)	<b>Cable Length</b> 10 Feet 15 Feet 20 Feet 25 Feet	<b>Nozzle</b> T - Threaded	<b>Wire Size</b> 35 - .035 Inches <sup>1</sup> 45 - .045 Inches 52 - .052 Inches <sup>2</sup> 62 - .062 Inches <sup>2</sup> 78 - .078 Inches <sup>3</sup> 94 - .094 Inches <sup>3</sup>	<b>Back End</b> E - Euro L - Lincoln External gas L1 - Lincoln 10, PF74/84 L2 - Lincoln Power MIG HT - Hobart/Tweco M - Miller Standard M1 - Miller Multimatic <sup>2</sup> X - No connector kit installed	<b>Handle</b> S - Short Trigger

## Weld Cable Cover



## Features & Benefits

- 1000 Denier Cordura with flame retardant coating
- Extremely lightweight
- Continuous temp rating: +250°F
- Momentary temp rating: 800°F
- Excellent UV protection
- Unaffected by water, oils, and mild solvents
- Excellent resistance to abrasion, weld spatter, puncture and tear resistance

# ABIMIG® A LW MIG Guns

## Body Cable Assembly

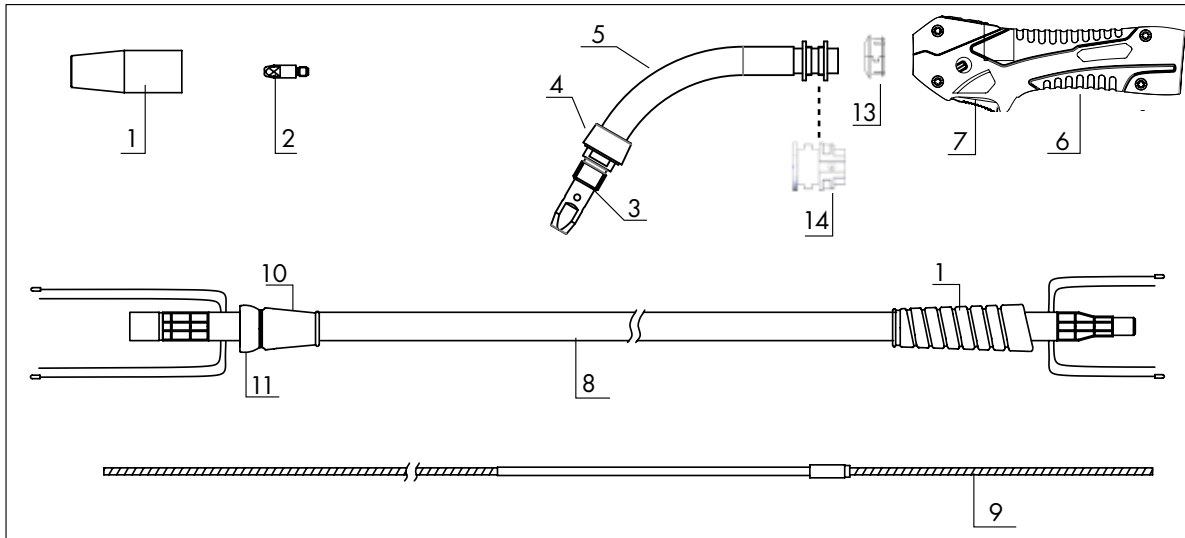

Item No.	Description	ABIMIG A 255	ABIMIG A 355	ABIMIG A 415
		Part No.	Part No.	Part No.
1	Nozzle			
2	Contact Tip			
3	Tip holder/Diffuser	See Page 9 & 10 for complete list of ABIMIG AT and ABIMIG A consumables.		
4	Adapter Piece			
5	Swanneck Assembly 60 Degree	767.0108	767.0109	767.0140
6	Handle Complete	180.0181	180.0181	180.0181
7	Trigger only	185.0135	185.0135	185.0135
8	Bikox 10 feet (415 cable shown)	160.H032	160.H046	160.H344
	Bikox 15 feet	160.H242	160.H248	160.H377
	Bikox 20 feet	160.H262	160.H264	160.H442
	Bikox 25 feet	160.H263	160.H265	160.1395
9	Liner	See Page 9 & 10 for complete list of ABIMIG AT and ABIMIG A consumables.		
10	Cable Support Front	400.D574	400.D574	400.D574*
11	Red Ball Joint Halves (2 Needed)	400.D561	400.D561	400.D561
12	Cable Support Rear	400.1010	400.1010	400.D518*
13	Protection Caps (2)	014.H282	014.H282	014.H283
14	Torch Body Support	400.1756**	-	-
N/S	Contact Tip Wrench	191.0001	191.0001	191.0001

\*Cable Support Front and Rear are included in ABIMIG A 415 as part of #8 Bikox cable.

\*\*This piece is only required for the ABIMIG A 255 model; two are needed



# Consumables

## Torch Model

### A/AT 255 Series

### A/AT 355 Series

### A/AT 415 Series

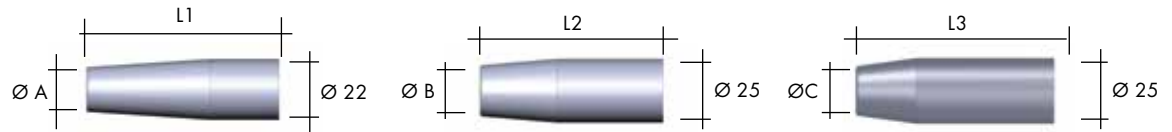

Nozzles	Ø A	L1	Part No.	Ø B	L2	Part No.	Ø C	L3	Part No.
Conical recess	Ø 1/2"	70 mm	145.D015*	Ø 1/2"	72 mm	145.D025	Ø 1/2"	85 mm	145.D243
Conical recess	Ø 9/16"	70 mm	145.D016	Ø 5/8"	72 mm	145.D026*	Ø 5/8"	85 mm	145.D244*
Conical recess	Ø 5/8"	70 mm	145.D011	Ø 3/4"	72 mm	145.D021	Ø 3/4"	85 mm	145.D245
Conical flush	Ø 1/2"	67mm	145.D013	Ø 9/16"	69 mm	145.D023	-	-	-
Conical flush	Ø 9/16"	67mm	145.D012	Ø 5/8"	69 mm	145.D022	-	-	-

\* Denotes Factory Standard

### A/AT 255 Series

### A/AT 355 & 415 Series

### A/AT 415 Series

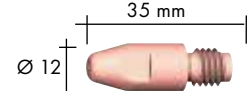
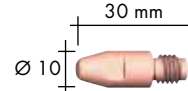

## Contact Tips

### M6

### M8

### M10

E-Cu <b>Standard Copper</b>	Ø .030"	140.0051		140.0114	-
	Ø .035"	140.0169		140.0214	-
	Ø .040"	140.0242		140.0313	-
	Ø .045"	140.0379		140.0442	-
	Ø .052"	-		140.0533	-
	Ø .062"	-		140.0587	-
	Ø .078"	-		140.0653	-
E-Cu for Al <b>Standard Copper for Aluminum</b>	Ø .030"	141.0001		141.0003	-
	Ø .035"	141.0004		141.0043	-
	Ø .040"	141.0006		141.0008	-
	Ø .045"	141.0010		141.0075	-
	Ø .052"	-		141.0055	-
	Ø .062"	-		141.0022	-
	Ø .078"	-		141.00677	-
CuCrZr <b>Heavy Duty Copper</b>	Ø .030"	140.0054		140.0117	-
	Ø .035"	140.0172		140.0217	* 140.1248
	Ø .040"	140.0245		140.0316	* 140.0348
	Ø .045"	140.0382		140.0445	* 140.0481
	Ø .052"	-		140.0536	* 140.0547
	Ø .062"	-		140.0590	* 140.0616
	Ø .078"	-		* 140.0656	* 140.0665
Silver-plated <b>Heavy Duty Copper Silver-plated</b>	Ø .030"	147.0054		147.0117	-
	Ø .035"	147.0172		147.0217	-
	Ø .040"	-		147.0316	-
	Ø .045"	147.0382		147.0445	* 147.0481
	Ø .052"	147.0519		147.0536	* 147.0547
	Ø .062"	-		147.0590	* 147.0616
	Ø .078"	-		147.0656	-
Ø .094"	-		-	* 147.0698	

\* Note: M6 tip is standard on ABIMIG® AT and A 255. M8 tips are standard on ABIMIG® AT and A 355 and 415 Series. M10 tips requires tip holder H4T-10-C and are optional for ABIMIG® AT and A 415. Only 415 Series models can accept .078" and .094" size contact tips. Additional configurations are available. Contact customer service for details at 1-800-542-4867

# ABIMIG® AT & A LW MIG Guns

## Consumables

### Tapered Consumables for ABIMIG 355 Air-cooled Torches

Call product department for more details.

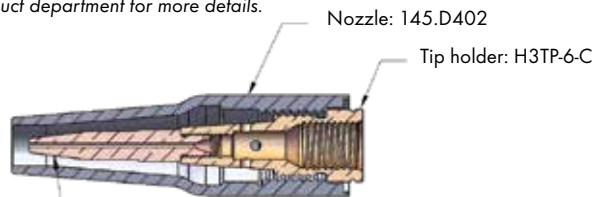

- Contact tip .030" M6 CU 173 P/N 140.1532
- Contact tip .035" M6 CU 173 P/N 140.1533
- Contact tip .045" M6 CU 173 P/N 140.1534
- Contact tip .035" M6 CZ Silver Plated 173 P/N 147.1609
- Contact tip .045" M6 CZ Silver Plated 173 P/N 147.1610

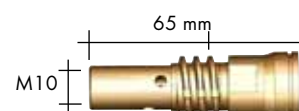
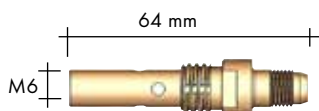

#### Contact tip holder (10 pcs.)

A/AT 255, 355, & 415	H2T-6-C	H3T-8-C	H4T-8-C*
A/AT 355	H3T-6-C	-	-

\* Optional HD M10 available P/N H4T-10-C

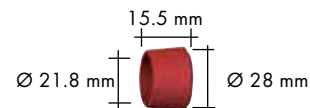
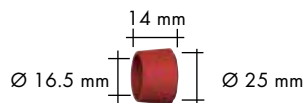
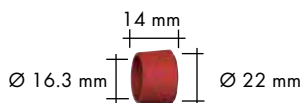

#### Adapter piece (1 pcs.)

ABIMIG A 255/355/415	767.D656	767.0107	016.D393
ABIMIG AT 255/355/415	767.D656	767.D668	016.D393

#### Neck Liners

ABIMIG AT Only

ABIMIG AT Model	Swanneck Item No. (see pgs. 4 & 5)	.035 - .045" Steel	.052 - .062" Steel	.024 - .035" Aluminum	.040 - .052" Aluminum
AT 255	004.0709	S3545	-	B2440	B4052
AT 355	014.0570	S3545	122.D045	B2440	B4052
	014.H538	S3545	122.D045	B2440	B4052
	014.H534	S3545	122.D045	B2440	B4052
	014.H515	S3545	122.D045	B2440	B4052
	014.H494	122.D088	122.D067	-	-
	014.H500	S3545XL	S5262XL	-	-
AT 415	014.D435	122.D077	122.D078	B2440	B4052
	014.D094	122.D077	122.D078	B2440	B4052
	014.D410	122.D077	122.D078	B2440	B4052
	016.0038	122.D077	122.D078	B2440	B4052

#### Torch Liners



Liner Type	Wire Size	A/AT 255 & 355 Series		A/AT 415 Series	
		for 15 ft	for 25 ft	for 15 ft	for 25 ft
Liner	Ø .035"-.045"	SI-3545-17PT	SI-3545-28PT	SI4-3545-17PT	SI4-3545-28PT
	Ø .052"-.062"	SI-5262-17PT**	SI-5262-28PT**	SI4-5262-17PT	SI4-5262-28PT
	Ø .078"-.094"	-	-	SI4-7894-17PT	SI4-7894-28PT
Combi PA liner	Ø .035"-.045"	128.9047	-	128.9047*	-
	Ø .052"-.062"	128.9050	-	128.9050*	-
Carbon PTFE liner	Ø .035"-.045"	127.9003	-	127.9003*	-
	Ø .052"-.062"	127.9006	-	127.9006*	-

\* 415 series torches require collet spacer P/N 130.9006. Item sold separately.

\*\* .052-.062" is not recommended for 255 series torches.

# ABIMIG® AT & A LW MIG Guns

## Connectors Kits

### Direct Plug Connector: Miller

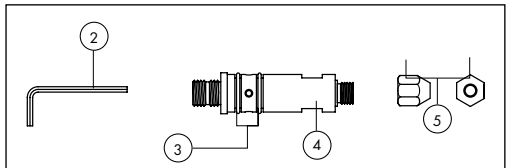

		255	355	415
Item No.	Description	Part No.	Part No.	Part No.
2	Allen Wrench 2.5mm	191.0017	191.0017	191.0017
3	O-Rings (2 required)	165.9006	165.9006	165.9006
4	Connector Plug Miller	501.9183	501.9183	501.9245
5	Liner Nut MR	272.9018	272.9018	272.9036

### Direct Plug Connector: Millermatic

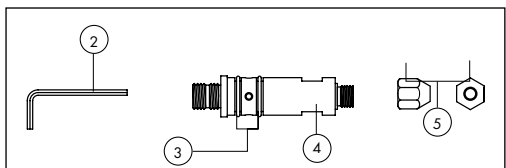

		255	355	415
Item No.	Description	Part No.	Part No.	Part No.
2	Allen Wrench 2.5mm	191.0017	191.0017	191.0017
3	O-Rings (2 required)	165.9006	165.9006	165.9006
4	Connector Plug Millermatic	501.9291	501.9291	-
5	Liner Nut MR	272.9018	272.9018	272.9036

### Direct Plug Connector: Hobart/Tweco

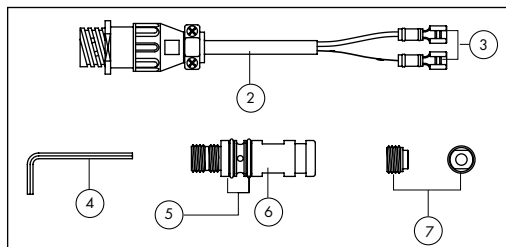

		255	355	415
Item No.	Description	Part No.	Part No.	Part No.
2	Trigger Lead Jumper HT	175.9120	175.9120	175.9120
3	Connector Wire 1/4" Male	175.9074	175.9074	175.9074
4	Allen Wrench 2.5mm	191.0017	191.0017	191.0017
5	O-Rings (2 required)	165.0025	165.0025	165.0025
6	Connector Plug HT	331.9003	331.9003	501.9246
7	Liner Nut HT/LN	272.9017	272.9017	272.9035

### Direct Plug Connector: Lincoln

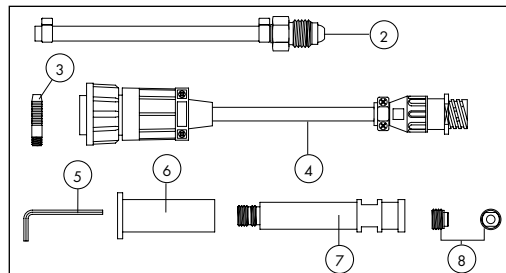

		255	355	415
Item No.	Description	Part No.	Part No.	Part No.
2	Gas Hose Assembly	102.9149	102.9149	102.9149
3	Gas Fitting with M6 THD	353.0002	353.0002	353.0002
4	Trigger Lead Jumper LN	175.9121	175.9121	175.9121
5	Allen Wrench 2.5mm	191.0017	191.0017	191.0017
6	Insulator Bushing	AC2030	AC2030	AC2030
7	Connector Plug L	501.9191	501.9191	501.9241
8	Liner Nut HT/LN	272.9017	272.9017	272.9035

### Direct Plug Connector: Lincoln 10

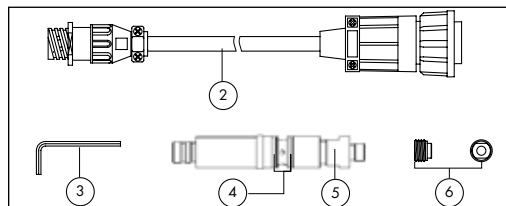

		255	355	415
Item No.	Description	Part No.	Part No.	Part No.
2	Trigger Lead Jumper LN	175.9121	175.9121	175.9121
3	Allen Wrench 2.5 mm	191.0017	191.0017	191.0017
4	O-Rings (2 required)	165.0025	165.0025	165.0025
5	Connector Plug HT	501.9247	501.9247	501.9247
6	Liner Nut HT/LN	272.9017	272.9017	272.9035

### Direct Plug Connector: Lincoln PowerMIG

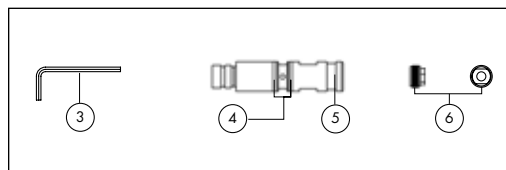

		255	355	415
Item No.	Description	Part No.	Part No.	Part No.
3	Allen Wrench 2.5 mm	191.0017	191.0017	191.0017
4	O-Rings (2 required)	165.0025	165.0025	165.0025
5	Connector Plug HT	501.9243	501.9243	501.2778
6	Liner Nut HT/LN	272.9017	272.9017	272.9035

Note: Connector part numbers apply to both ABIMIG AT and ABIMIG A torches.

The paper in this printed piece is 100% PCW and comes from forest that are certified and managed for sustainability. By using this paper, we save 130 trees, 12,800 gallons of water and eliminated 2870 pounds of solid waste.

Binzel S.A DE C.V.  
Municipio Pabellon de Arteaga 102  
Valle De Aguascalientes, 20358  
San Francisco de los Romo, Ags. Mexico  
Phone: +52(499) 973.0133  
Fax: +52(499) 973.1388  
E-Mail: info@binzel.com.mx



ABICOR BINZEL USA, Inc.  
650 Medimmune Court, Suite 110  
Frederick, MD 21703  
Phone: 800.542.4867  
Fax: 301.846.4497  
E-Mail: customerservice@abicorusa.com

[www.binzel-abicor.com](http://www.binzel-abicor.com)